

# In the Thick of It

Keep the hydrolysis process  
**simple | affordable | safe**  
 for all sized plants



## What is PONDUS™ Thermo-Chemical Hydrolysis Process (TCHP)?

PONDUS, an alkaline process, utilizes low grade heat (140 °F to 160 °F) and sodium hydroxide for sludge hydrolysis. A typical PONDUS system consists of a hydrolysis reactor, hot water heat exchanger, chemical dosing station, pumps, instrumentation and controls. PONDUS reduces sludge viscosity, enhances biogas production and improves sludge dewaterability.







## The PONDUS Difference

- No heat exchangers needed to cool sludge after hydrolysis to maintain an optimum digester temperature
- No pressure vessel required
  - ✓ Safer operation
  - ✓ Specialized steam operator is not necessary
  - ✓ Reduces operating and energy costs
- Combination of caustic soda (NaOH) and heated water, 140 °F to 160 °F, break down the cell walls
- Minimal equipment needed: high-efficiency heat exchanger, progressive cavity pumps and a reactor operating under at atmospheric pressure

## PONDUS is Simple to Operate

PONDUS is designed to utilize low grade heat (from hot water), rather than steam, as a heat source for sludge hydrolysis. A Certified Steam Boiler License is not required to operate the system. PONDUS' design allows it operate the atmospheric pressure without involving a pressurized vessel. Maintaining PONDUS is easy. Typical maintenance includes: pump maintenance, heat exchanger cleaning, and sodium hydrolyzed refilling.

## PONDUS Optimizes Your Sludge Treatment Process

-  Reduce Viscosity of Thickened WAS up to **80%**
-  Reduce Anaerobic Digestion Volume up to **50%**
-  Reduce Biosolids Disposal Costs up to **30%**
-  Increase Biogas Production up to **30%**
-  Reduce Polymer Consumption at Dewatering up to **20%**
-  Reduce Digester Foaming



## PONDUS is a Cost-Effective Choice

- Simple operation requires little day-to-day plant supervision
- Fully automatic process runs 24/7 year-round
- 99% uptime; minimal estimated downtime for maintenance and repairs
- Designed using standard industrial control system equipment
- Compact; small footprint solution for all sized plants

## PONDUS Step-By-Step

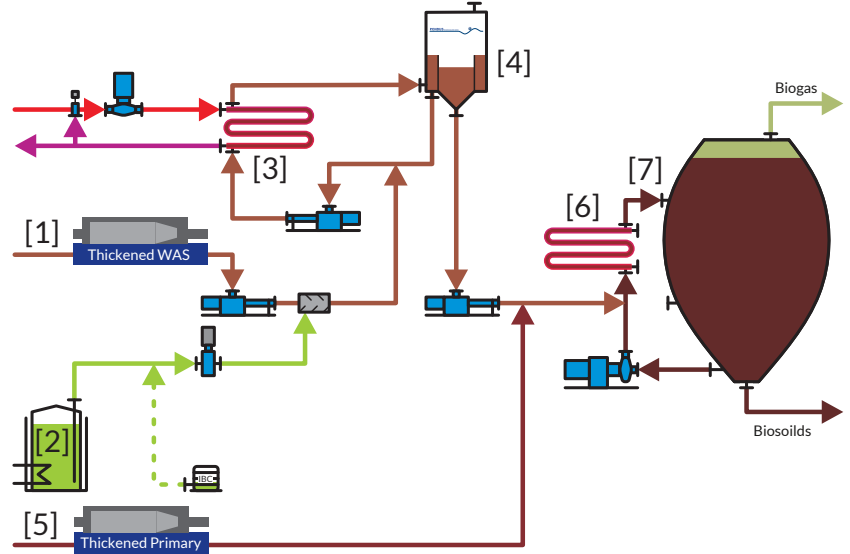

[1] Thickened WAS is mixed with a small dose of [2] caustic soda (1.75 l/m<sup>3</sup>).

[3] Sludge, up to 7% total solids (TS), is heated in a loop through a high-efficiency heat exchanger. Sludge above 7% TS or high viscosity sludge can use saturated steam as a heat source.

[4] Sludge is fed into PONDUS and goes through hydrolysis. The sludge is heated with 140 °F to 160 °F water from a Combined Heat and Power (CHP) unit or boiler. Retention time may differ in reactor zones due to varying sludge properties. The reactor operates under atmospheric pressure and is connected to the atmosphere or bio-filter. After the hydrolysis process, sludge leaves the reactor close to a neutral pH level and the remaining thermal energy can be used in the anaerobic digester [7].

[5] Thickened primary sludge and hydrolyzed sludge is mixed to achieve an ideal mesophilic temperature of the combined sludge and then pumped into the digester [7]. If needed, additional heat can be brought into the digester through a [6] heat exchanger.

## PONDUS Full Scale Installations

Wastewater Treatment Plant	Location	Year Built	Plant Size (MGD)	After PONDUS	
				Additional Gas Production	Note
Kläranlage Gifhorn	Gifhorn, Germany	2005	14	27%	24-hr operation
Kläranlage Ratekau	Ratekau, Germany	2007	13	38%	12-hr operation, Class A possible
Nordhorn Kommunale Betriebe AöB	Nordhorn, Germany	2014	16	25%	24-hr operation, Class A possible
Kläranlage Uelzen	Uelzen, Germany	2014	13	31%	24-hr operation
Kenosha Wastewater Treatment Plant	Kenosha, Wisconsin	2015	28	27%	24-hr operation since March 2016
Kläranlage Wolfsburg	Wolfsburg, Germany	2016	34	N/A*	24-hr operation
Löhne-Rießel Wastewater Treatment Plant	Löhne, Germany	2019 Start-Up	14		Pending Start-Up
Wuwei Sludge Treatment Center	Wuwei, China	2020 Start-Up	106		Pending Start-Up

\* PONDUS and the anaerobic digester were implemented at the same time. There is no historical biogas production data to compare.